

## DRINKS | Vitrines de boissons

RÉFRIGÉRATEUR POUR BOISSONS ► LIGNE DC ► PORTES A CHARNIÈRE

DC 1000H

CUSTOMIZATION  
AVAILABLE  
PERSONALIZZAZIONE  
DISPONIBILE

+1° | +10°



45 mm

-1°C  
+6°CC  
ENERGY  
CLASS+40°C  
75RHGAS  
R290

## DÉTAILS

Commutateurs  
d'éclairage  
indépendants pour  
lampe interne et  
couvercleThermostat  
numériqueLampe LED interne  
verticaleSerrure montée de  
série

## CARACTÉRISTIQUES GÉNÉRALES

- Réfrigérateur vertical pour boissons 1000 l avec panneau publicitaire
- Acier laqué blanc pour la face interne et la face externe
- Refroidissement ventilé
- Cycle de dégivrage automatique par arrêt du compresseur
- Agent moussant : Cyclopentane (45 mm par côté)
- Thermostat numérique
- Porte à fermeture automatique
- Joint d'étanchéité amovible
- Clayettes réglables: 8 pièces
- Commutateurs indépendants pour l'éclairage interne et le couvercle
- Verre de sécurité trempé
- Serrure montée de série
- Lampe LED interne verticale/Lampe LED pour le couvercle
- Roues N° 4 pour positionnement facile
- Classe énergétique: C

## SPÉCIFICATIONS TECHNIQUES

Capacité	1000 L
Température	K2 (-1°C-+6°C)
Consommation	3.019 kWh/24h
Puissance nominale	500 W
Niveau de bruit	64 dB(A)
Poids net	170 Kg
Poids brut	199 Kg
Dimensions extérieures (LxPxH mm)	1200x730x2035
Dimensions internes (LxPxH mm)	1110x595x1525
Dimensions de l'emballage (LxPxH mm)	1255x770x2136
Quantités de chargement 20'/40'/40'HQ	13/27/27

## CERTIFICATIONS

CE  RoHS

## DIMENSIONS DU PRODUIT

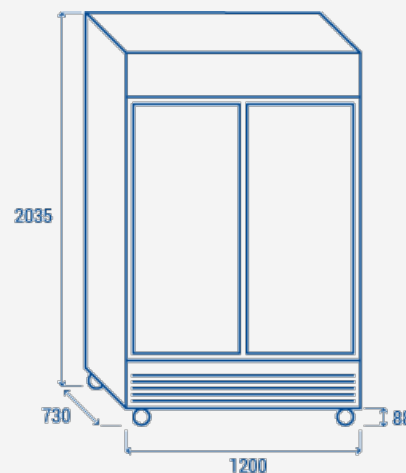

COOL HEAD EUROPE

We make the world a cooler place



www.coolheadeurope.com